

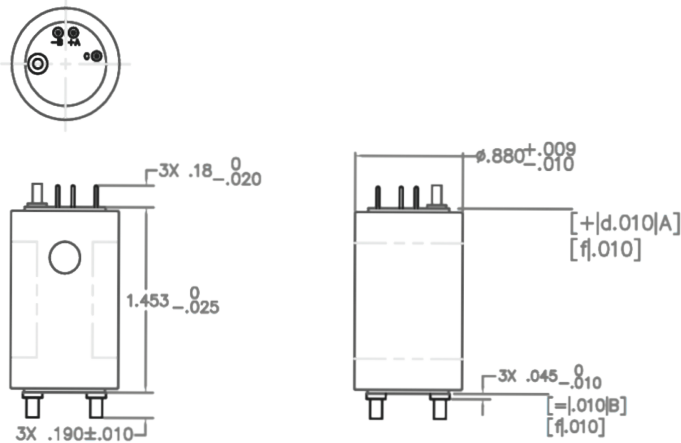

SAP-12116 Thermal Battery

Case and header A-286 steel



Specifications

Part Number	SAP-12116
Weight	28 g (0.06 lbs)
Nominal Volume	0.62 in ³
Dimensions	Width: 22 mm (0.88 in)
	Length: 37 mm (1.45 in)
Voltage	15 V to 20 V
Load	150 ± 5 Ω
Rise Time	0.03-0.15 sec to 15 V
Typical	0.05 sec to 15 V
Life	11 sec min to 15 V
Activation	25,000 g (2 ms max) inertial ignitor
Indicator	93°C (200°F) paint dot
Operating Temperature	-32 to 49°C (-25 to 120°F)
Shock	55,000 g, 2 ms max
Spin	60 (rps)
Terminal Material	52 iron nickel alloy gold plated

