

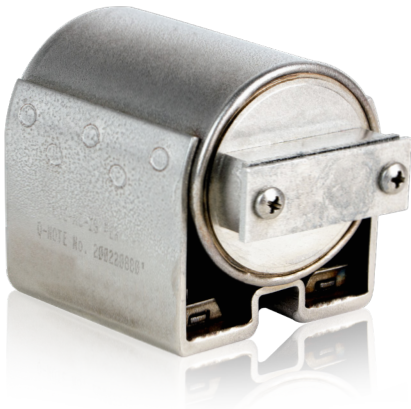

## EAP-12297 Thermal Battery

Case and header material: Type 304 Stainless Steel



### Specifications

Part Number	EAP-12297
Weight	148.3 g (0.3 lbs)
Nominal Volume	3.3 in <sup>3</sup>
Dimensions	Width: 50 mm (2.0 in) Length: 54 mm (2.1 in)
Voltage	24 to 34 VDC
Load	Base load of 2 A 6 A pulse @ 5 sec for 50 ms Two 6 A pulses @ 15 & 30 sec for 20 ms
Rise Time	1.0 sec
Life	30 sec
Activation	EP-250-1
Activation Indicator	Temperature decal
Operating Temperature	-32° to 71°C (-26° to 160°F)
Vibration	Random vibration for 30 sec
Shock	60 g peak @ 1500-5000 Hz
Terminal Material	Nickel iron alloy hot soldered

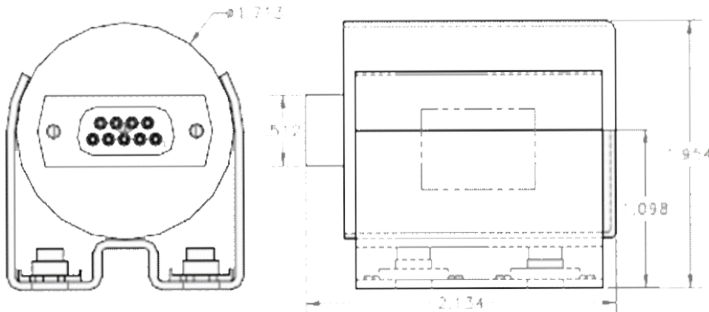

TYPICAL PERFORMANCE: RISE TIME: (COLD: .605 SEC. TO 24.0 Vdc; HOT: .400 SEC. TO 24.0 Vdc)

